

START HERE!

READ ME FIRST

Don't be a hero and muscle through this installation without reading these fitting instructions first! Improper installation of this gear may void certain aspects of your warranty.

Before you begin, take a moment and open all your Front Runner rack kit boxes and gather the assembly instructions for the various components.

A complete kit will contain:

1. A Front Runner Mounting System specific to your vehicle
2. A Front Runner Rack Tray or Load Bar Slats

This document will guide you through the assembly of the mounting system and assist you in fitting the roof rack tray or load bars to your specific vehicle.

Please refer to the next page for a list of all the components, quantities and tools required.

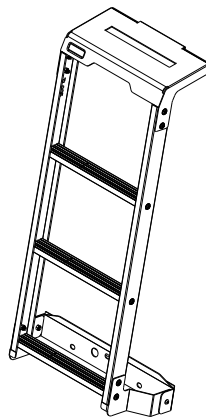

IMPORTANT WARNING!

IT IS CRITICAL THAT ALL FRONT RUNNER PRODUCTS BE PROPERLY AND SECURELY ASSEMBLED AND ATTACHED TO YOUR VEHICLE. IMPROPER ATTACHMENT COULD RESULT IN AN AUTOMOBILE ACCIDENT, AND COULD CAUSE SERIOUS BODILY INJURY OR DEATH. YOU ARE RESPONSIBLE FOR ASSEMBLING AND SECURING ALL FRONT RUNNER PRODUCTS TO YOUR VEHICLE, CHECKING THE ATTACHMENTS PRIOR TO USE, AND PERIODICALLY INSPECTING THE PRODUCTS FOR ADJUSTMENT, WEAR AND DAMAGE. THEREFORE, YOU MUST READ AND UNDERSTAND ALL OF THE INSTRUCTIONS AND PRECAUTIONS SUPPLIED WITH YOUR FRONT RUNNER PRODUCT PRIOR TO INSTALLATION OR USE. IF YOU DO NOT UNDERSTAND ALL OF THE INSTRUCTIONS AND CAUTIONS, OR IF YOU HAVE NO MECHANICAL EXPERIENCE AND ARE NOT THOROUGHLY FAMILIAR WITH THE INSTALLATION PROCEDURES, YOU SHOULD HAVE THE PRODUCT INSTALLED BY A PROFESSIONAL INSTALLER OR OTHER QUALIFIED PERSONNEL.

NOTE: Front Runner will not be responsible for any damage caused by the failure to install the product according to these instructions.

Please call us if you have any questions about the installation of this product.



1 GET ORGANIZED

IN THE BOX

- | | | |
|----|------|------------------------------|
| 1 | 1 X | Ladder top Assembly |
| 2 | 2 X | Ladder Sides |
| 3 | 2 X | Bottom mount Support Bracket |
| 4 | 2 X | Bottom Mount Bracket |
| 5 | 3 X | Ladder Steps |
| 6 | 6 X | M6 x 16 Flange Button Head |
| 7 | 11 X | M6 Nyloc Nut |
| 8 | 2 X | M6 x 12 Button Head Screw |
| 9 | 6 X | M6 x 25 Thread Forming Screw |
| 10 | 3 X | M6 x 19 x 1 Flat Washer |
| 11 | 11 X | M6 Nut Caps |

TOOLS NEEDED

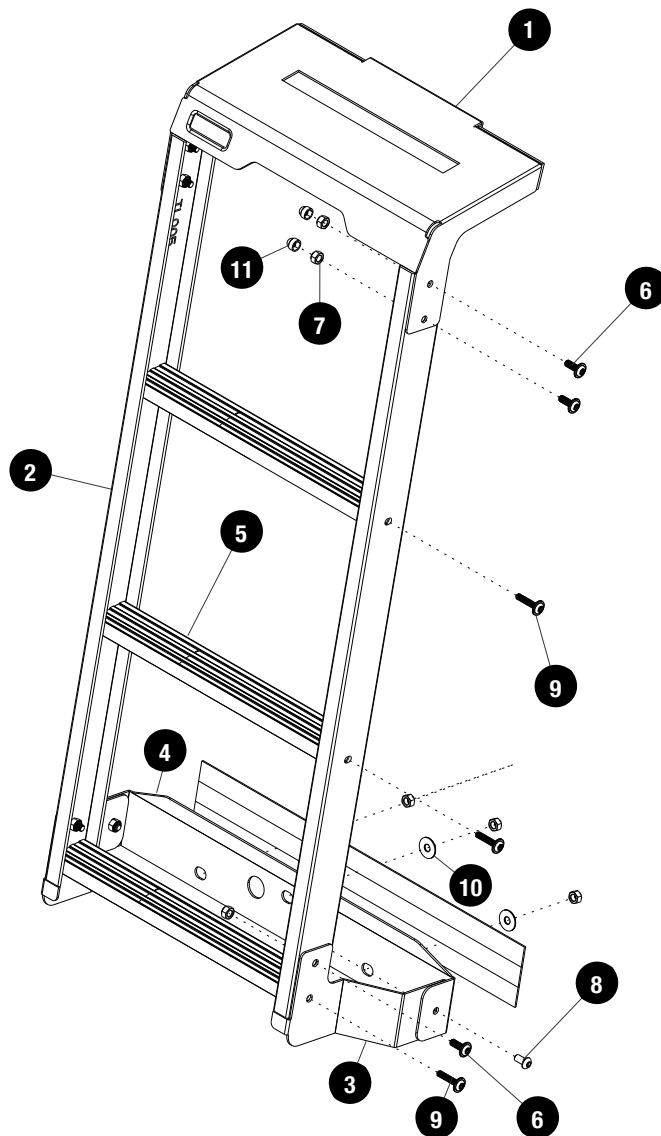
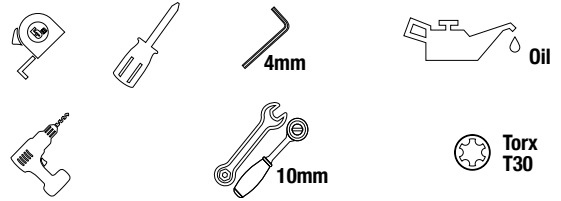

2

FIT AND SECURE

2.1

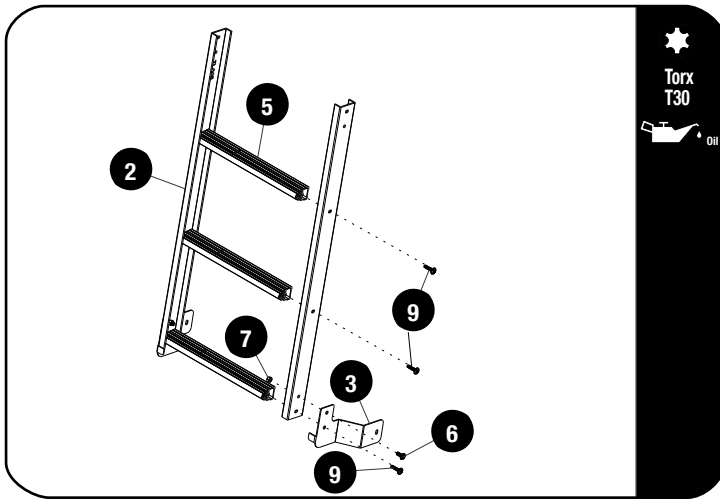

Assemble the left and right ladder sides (Item 2) together with the ladder steps (item 5) using the M6 x 25 Thread forming Screw (item 9) as shown.

Assemble the bottom stem (Item 5) together with the bottom mount of the ladder (Item 3) using a M 6 x 25 Thread Forming Screw (Item 9) and M6 x 16 Flange Button Head and M6 Nyloc Nut (Item 7) as shown.



Use a little oil on screw threads before inserting. Note these are thread forming Screws.



Tightening Torque 8-10Nm / 5.9 ft lb - 7.38 ft lb. Take care when using a cordless driver

2.2

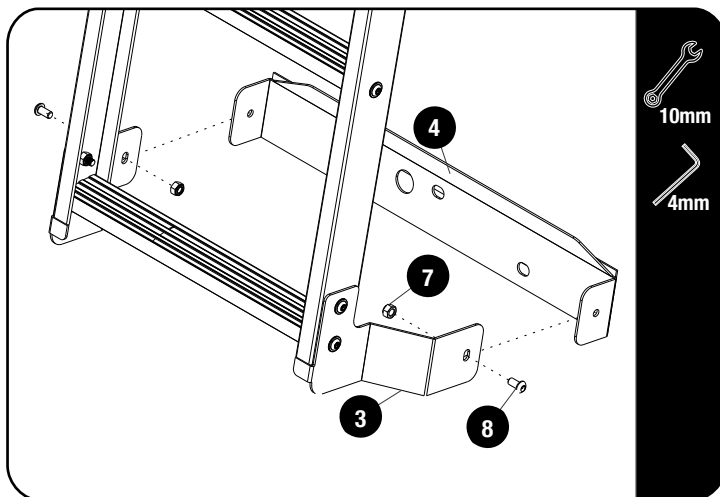

Assemble the Bottom Mount (Item 4) to the side support Bracket (Item 3) Using the M6 x 12 Button head Bolt and Nyloc Nut (Item 7 & 8)

Do not Fully tighten at this point.

2.3

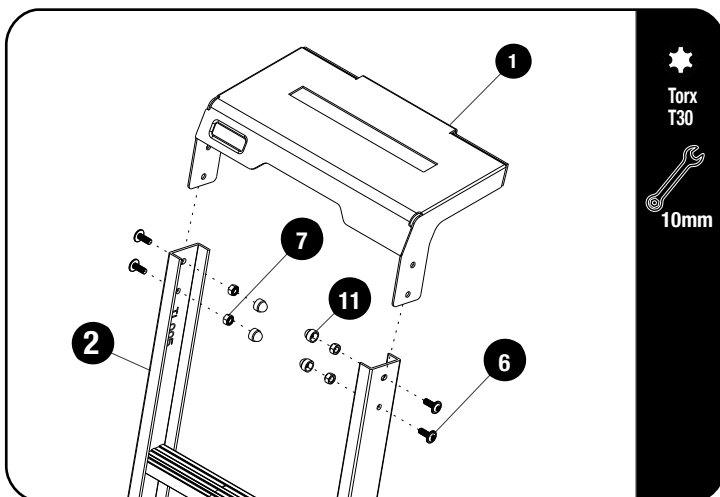

Assemble the top Mount Bracket (Item 1) to the Ladder sides (Item 2) using M6 x 16 Button Head Flange Bolts, M6 Nyloc Nut and M6 Nut Cap (Item 6, 7 & 11) shown.

Fully tighten all the bolts.

Place the M6 Nut Caps on the M6 Nylock Nuts.

2.4

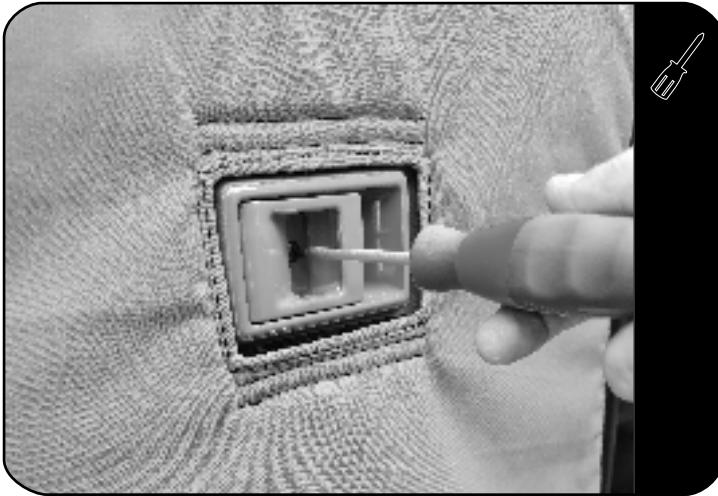

Open the vehicle left hand rear door. Loosen and remove the screw securing the latch to the inside of the rear door using a Phillips Screw Driver.

2.5



Push the latch forward to release and then to the right to unhook the latch from the door panel.

2.6

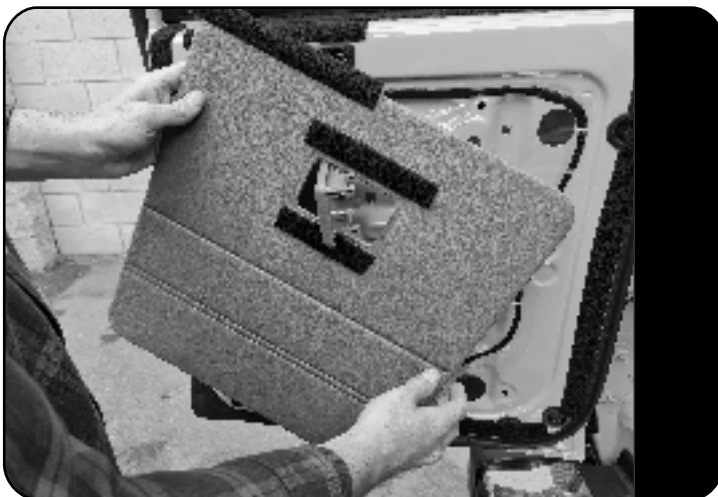

With the latch free, carefully unclip the door panel and remove by feeding the latch back through the panel cut-out.

2.7

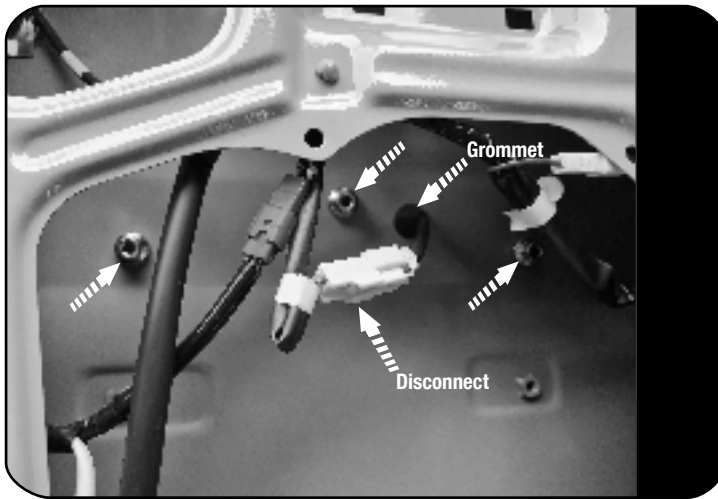

To Remove the number Plate light peel back the plastic cover to expose the wiring and door fasteners.

Disconnect the electrical connector.

Loosen the three nuts and grommet, and remove the light unit from the vehicle.

2.8

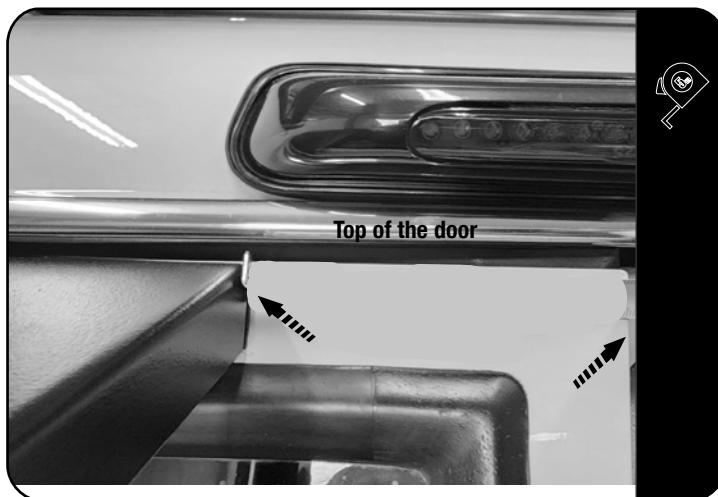

Pull the rubber door seal at the top of the inside door away from the door. Hook the top of the ladder over the top of the door. The middle lip must go between the vehicle door and the rubber door seal and the two side tabs on the outside of the door.

Line up the Ladder with the shunt line of the door.

Refit the rubber door seal at the top of the inside door.

2.9

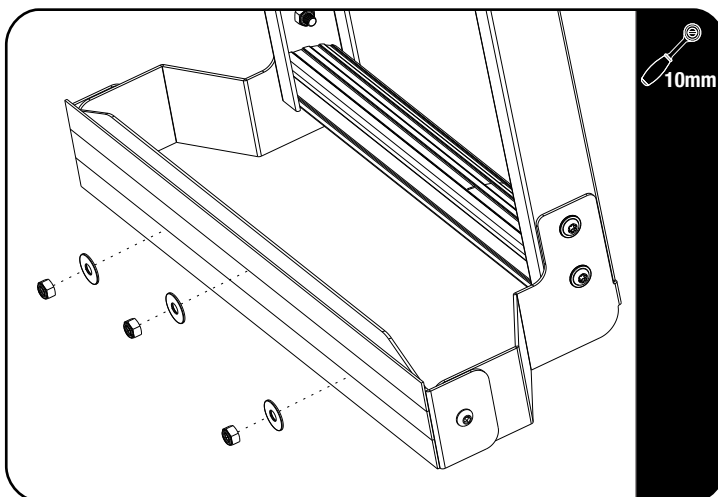

Line up the holes in the Bottom Support (Item 7) with the holes in the door. Refit the light unit pushing the threaded studs through the holes in the Support Bracket, through the door. Loosely secure the light unit using three M6 Large Flat Washers (Item 4) and the OEM nuts previously removed.

Refit the grommet, making sure it seats properly.

Fully tighten the nuts assembled in 2.2 and the 3 M6 Nyloc Nuts on the inside of the door.



Do not over tighten.

Reconnect the electrical fitting previously disconnected in 2.7.

Refit the plastic sheet, door panel and latch.

3

COMPLETION

3.1

Congratulations! You did it. Take a step back and admire your work!



4

INSTALL OTHER VEHICLE AND RACK ACCESSORIES

Now's the time to visit your favorite Front Runner dealer in person or online.

IMPORTANT!

FRONT RUNNER RACK KITS OFTEN HAVE A HIGHER LOAD RATING THAN THE VEHICLES THEY ARE MOUNTED TO. PLEASE REFER TO YOUR SPECIFIC VEHICLE MANUFACTURER FOR A RECOMMENDED ROOF RATING. FRONT RUNNER CANNOT BE RESPONSIBLE FOR IMPROPER LOADING BEYOND THE VEHICLE MANUFACTURER'S STATED LOAD CAPACITY.

Be sure to tag us. We love to see our gear in action! #FrontRunnerOutfitters #BornToRoam

Share your adventures on:  