

START HERE!

READ ME FIRST

Don't be a hero and muscle through this installation without reading these fitting instructions first! Improper installation of this gear may void certain aspects of your warranty.

Before you begin, take a moment and open all your Front Runner rack kit boxes and gather the assembly instructions for the various components.

A complete kit will contain:

1. A Front Runner Mounting System specific to your vehicle
2. A Front Runner Rack Tray or Load Bar Slats

This document will guide you through the assembly of the mounting system and assist you in fitting the roof rack tray or load bars to your specific vehicle.

Please refer to the next page for a list of all the components, quantities and tools required.

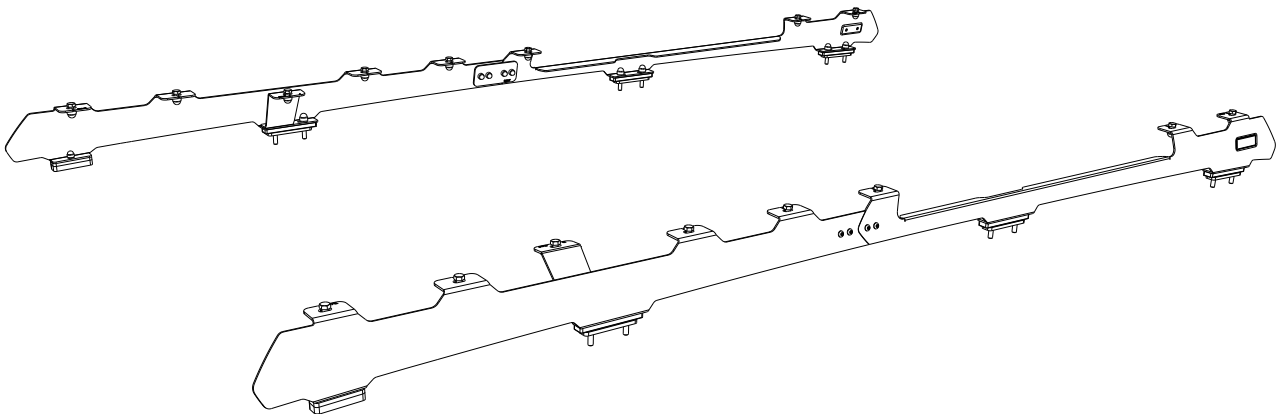

IMPORTANT WARNING!

IT IS CRITICAL THAT ALL FRONT RUNNER PRODUCTS BE PROPERLY AND SECURELY ASSEMBLED AND ATTACHED TO YOUR VEHICLE. IMPROPER ATTACHMENT COULD RESULT IN AN AUTOMOBILE ACCIDENT, AND COULD CAUSE SERIOUS BODILY INJURY OR DEATH. YOU ARE RESPONSIBLE FOR ASSEMBLING AND SECURING ALL FRONT RUNNER PRODUCTS TO YOUR VEHICLE, CHECKING THE ATTACHMENTS PRIOR TO USE, AND PERIODICALLY INSPECTING THE PRODUCTS FOR ADJUSTMENT, WEAR AND DAMAGE. THEREFORE, YOU MUST READ AND UNDERSTAND ALL OF THE INSTRUCTIONS AND PRECAUTIONS SUPPLIED WITH YOUR FRONT RUNNER PRODUCT PRIOR TO INSTALLATION OR USE. IF YOU DO NOT UNDERSTAND ALL OF THE INSTRUCTIONS AND CAUTIONS, OR IF YOU HAVE NO MECHANICAL EXPERIENCE AND ARE NOT THOROUGHLY FAMILIAR WITH THE INSTALLATION PROCEDURES, YOU SHOULD HAVE THE PRODUCT INSTALLED BY A PROFESSIONAL INSTALLER OR OTHER QUALIFIED PERSONNEL.

NOTE: Front Runner will not be responsible for any damage caused by the failure to install the product according to these instructions.

Please call us if you have any questions about the installation of this product.



1 GET ORGANIZED

IN THE BOX

- | | | |
|----|------|---------------------------|
| 1 | 2 X | Front Foot Rail / LH & RH |
| 2 | 2 X | Rear Foot Rail / LH & RH |
| 3 | 1 X | Front Support LH |
| 4 | 1 X | Front Support RH |
| 5 | 2 X | 6mm Front Spacer |
| 6 | 2 X | 10mm Front Spacer |
| 7 | 2 X | Joiner Plate |
| 8 | 10 X | M6 Nut Cap |
| 9 | 10 X | M6 Nyloc Nut |
| 10 | 2 X | M6 x 30 Countersink Screw |
| 11 | 16 X | M8 x 20 Hex Bolt |
| 12 | 28 X | M8 Flat Washer |
| 13 | 16 X | M8 Nyloc Nut |
| 14 | 28 X | M8 Nut Cap |
| 15 | 2 X | M8 x 45 Hex Bolt |
| 16 | 10 X | M8 x 40 Hex Bolt |

IN THE BOX

- | | | |
|----|-----|--------------------------|
| 17 | 2 X | M6 Flat Washer |
| 18 | 8 X | M6 x 16 Button Head Bolt |
| 19 | 6 X | 6mm Spacer |
| 20 | 6 X | 10mm Spacer |
| 21 | 2 X | Double Sided Tape |

TOOLS NEEDED

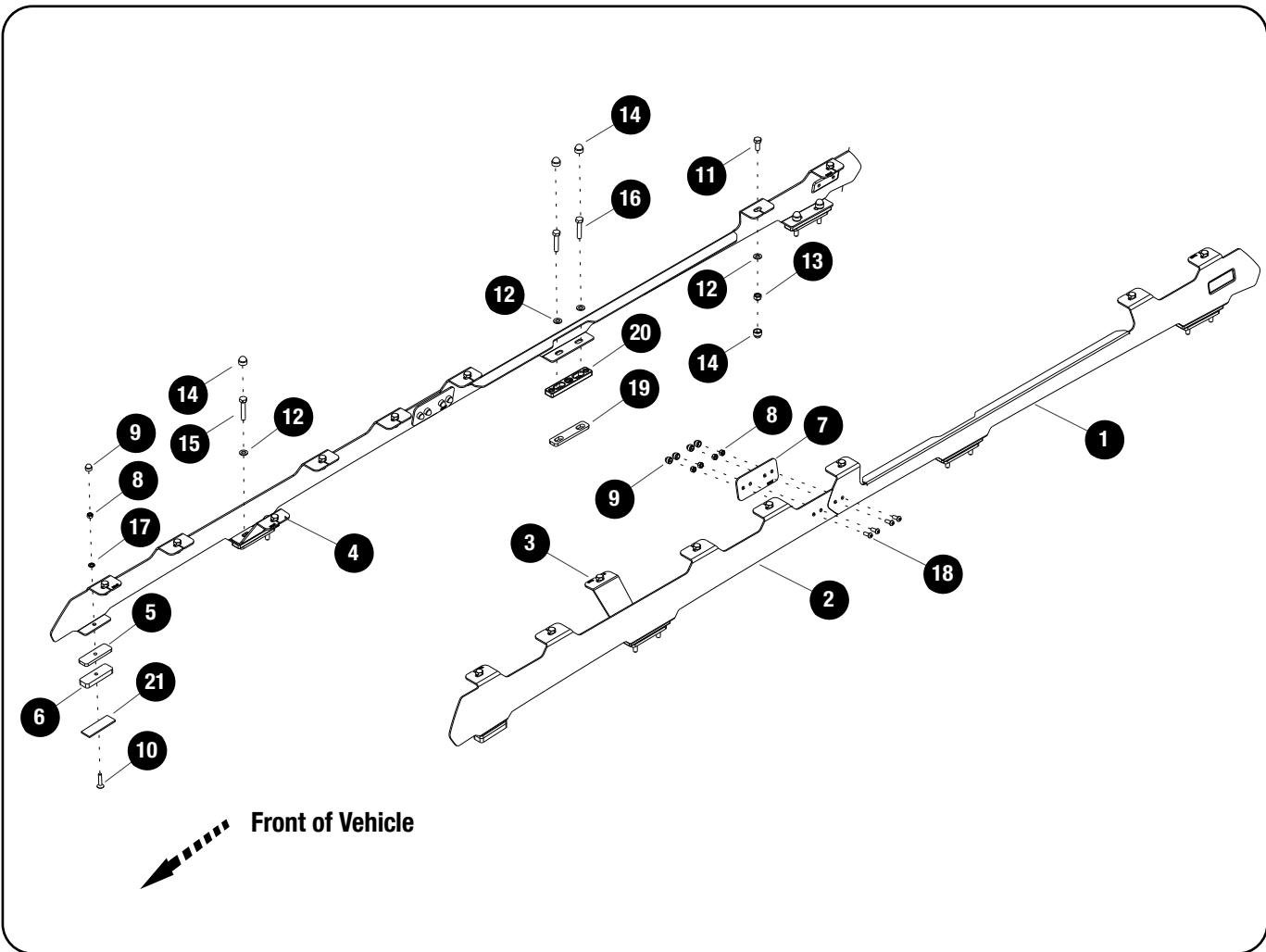
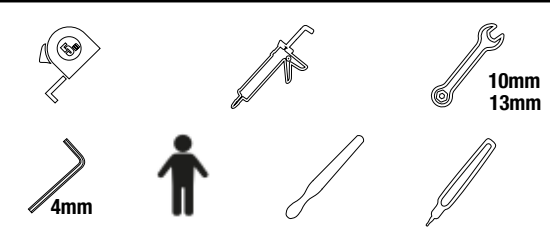

2

FIT AND SECURE

2.1

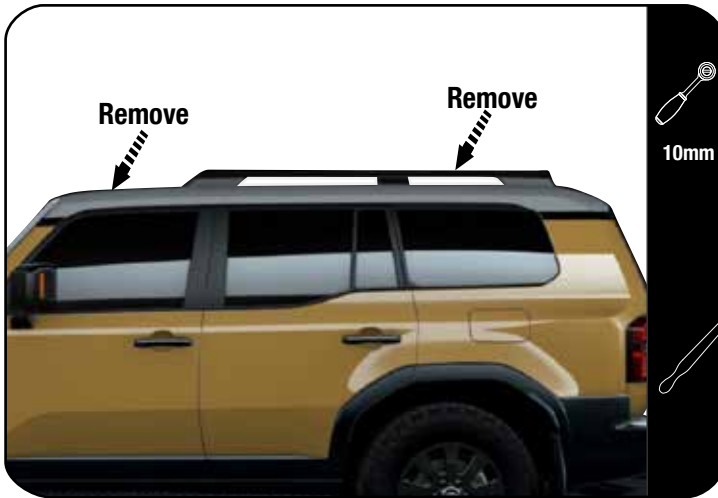

Remove the Factory Roof Rails and Saddle Brackets.

If you don't have Roof Rails fitted, remove the factory covers and Saddle brackets.

Also remove the front part of the ditch trim.

2.2

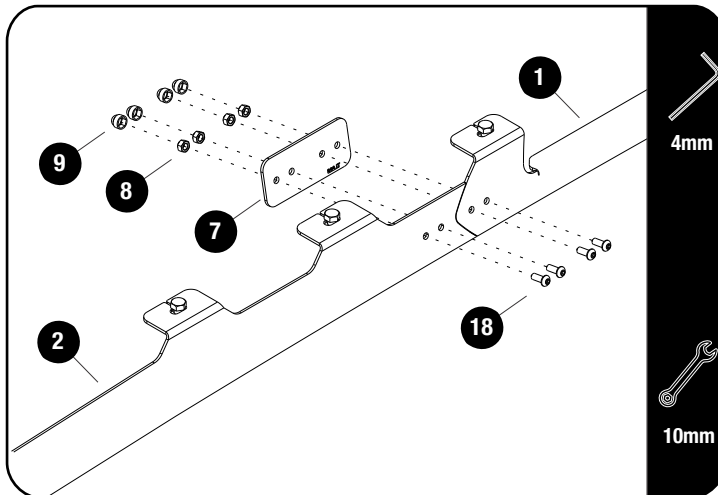

Tightening Torque:

M6 : 8-10Nm / 5.9 ft lb - 7.38 ft lb



Assemble the Front and Rear Foot Rails (Items 1 & 2) using the Joiner Plate (Item 7), M6 x 16 Button Head Bolt and M6 Nyloc Nuts (Items 8 & 18)

Do this on both left and right foot rails.

Fully tighten before placing M6 Nut Caps (Item 9) over all Nyloc Nuts.

2.3

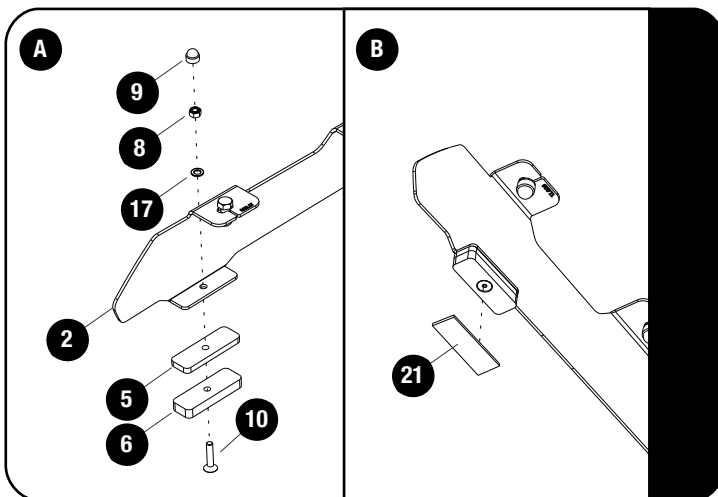

Assemble the 6mm and 10mm Spacers (Item 5 & 6) to the Front Foot Rail (Item 2) using a M6 x 30 Countersink bolt, M6 Flat Washer and M6 Nyloc Nut (Items 8, 10 & 17) as shown.

Place a M6 Nut Cap (Item 9) on the Nyloc Nut. Do this on both left and right side Foot Rails.



Apply Double Sided Tape (Item 21) to the bottom of the Spacer.



The backing of the tape will be removed in 2.6.

2.4

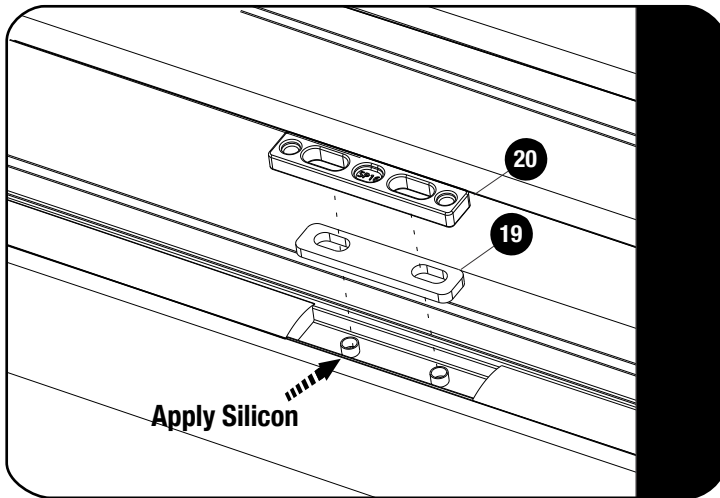

Apply a bead of silicon in and around each mounting hole.

Place the 6mm and 10mm Spacers (Items 19 & 20) as shown into the ditch where the saddle brackets was removed in 2.1.

Do this on all six mounting points.

2.5

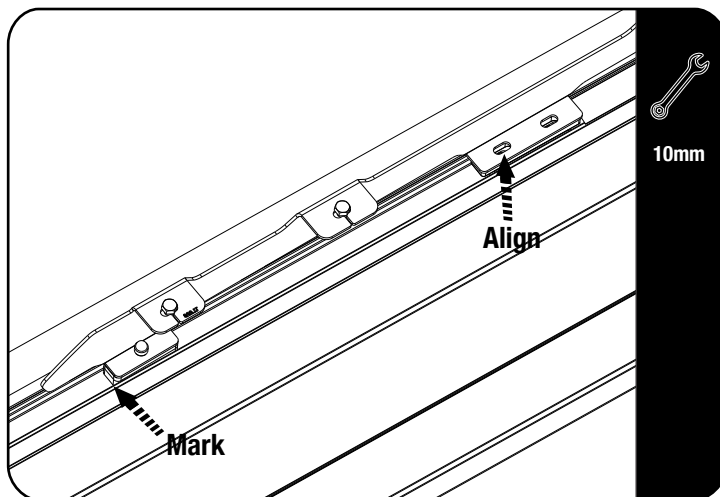

Place the Foot Rail in the ditch and align the slots of the mount with the OEM holes in the vehicle.

Mark the position of the front foot in the ditch.

Remove the rail from the vehicle.

Do this on the left and right side of the vehicle.

2.6

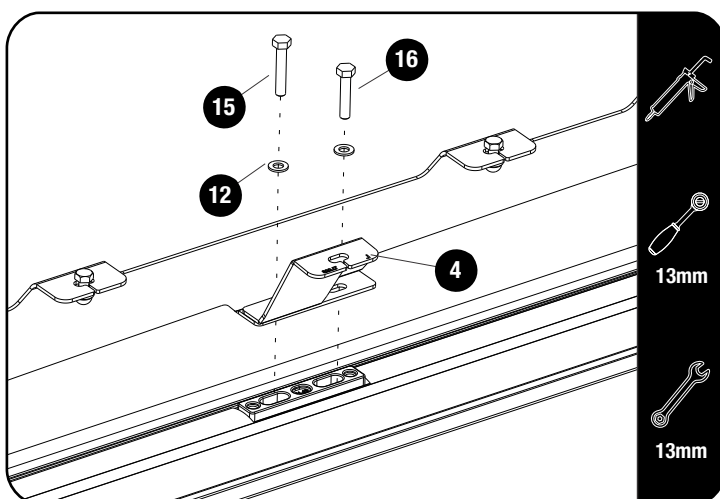

Tightening Torque:

M8 : 15-20Nm / 11.06 ft lb - 14.75 ft lb



Remove the backing from the tape before placing the Foot Rail back into the ditch.

Ensure that the Front Foot is aligned with the mark made in 2.5 before securing the rail.

Place the Front Support (Item 4) on top of the front most Foot Rail mount.

Loosely secure the Front Support using an M8 x 45 Hex and M8 Flat Washer (Items 12 & 15) as shown.

Loosely fit M8 x 40 Hex Bolts with M8 Flat Washers (Items 12 & 16) into the rest of the mounting points.

Fully tighten all fasteners.



Tip:

Use a socket wrench to secure the bolt holding the Support Bracket.

3

FIT AND SECURE

3.1

Refer to RRSUNI when assembling your Slimline II Tray.



3.2

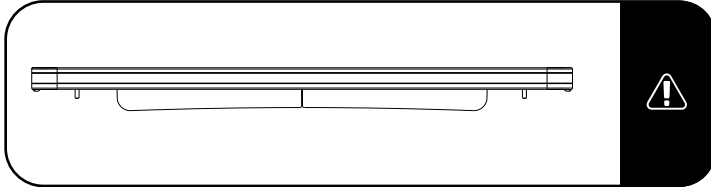

Make sure that the wind deflector is installed before you proceed to the next step.

3.3

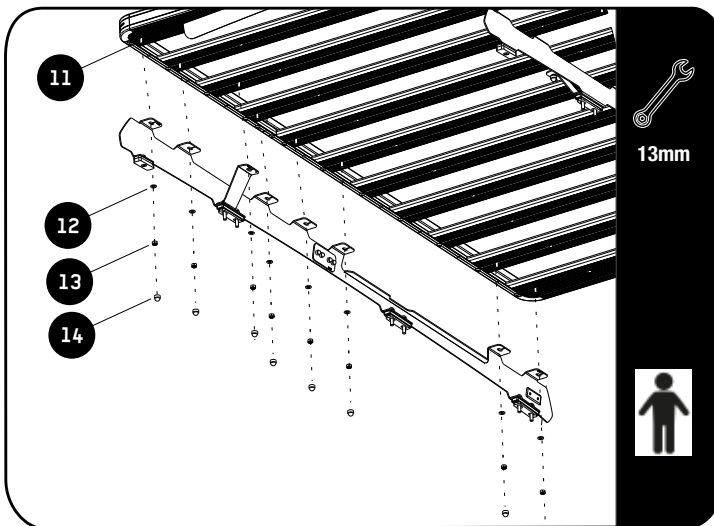

Tightening Torque:

M8 : 15-20Nm / 11.06 ft lb - 14.75 ft lb



With the help of a friend, place the Rack onto the Foot Rails.

Secure the Roof Rack to the Foot Rails using M8 x 20 Hex Bolts, M8 Flat Washers and M8 Nyloc Nuts (Items 11, 12 & 13) as shown.

3.4

Center the rack and tighten fully. Use M8 Nut Caps (Items 14) to finish off the nuts.



4

COMPLETION

4.1

Congratulations! You did it. Take a step back and admire your work!



5

INSTALL OTHER VEHICLE AND RACK ACCESSORIES

Now's the time to visit your favorite Front Runner dealer in person or online.

IMPORTANT!

FRONT RUNNER RACK KITS OFTEN HAVE A HIGHER LOAD RATING THAN THE VEHICLES THEY ARE MOUNTED TO. PLEASE REFER TO YOUR SPECIFIC VEHICLE MANUFACTURER FOR A RECOMMENDED ROOF RATING. FRONT RUNNER CANNOT BE RESPONSIBLE FOR IMPROPER LOADING BEYOND THE VEHICLE MANUFACTURER'S STATED LOAD CAPACITY.

Be sure to tag us. We love to see our gear in action! #FrontRunnerOutfitters #BornToRoam

Share your adventures on: 